

# Z100™ Navigator

Reference Manual

Version 2.1b

T. +61 2 9807 8855

F. +61 2 9807 8844

E. [info@edaq.com](mailto:info@edaq.com)

. [www.edaq.com](http://www.edaq.com)

© 1991–2008 WonATech Co. Ltd.

All rights reserved.

# Contents

<b>Z100™ Electrochemical Impedance Analyzer .....</b>	<b>6</b>
<b>Available Techniques .....</b>	<b>7</b>
List of Techniques .....	7
Potentiostatic Electrochemical Impedance Spectroscopy (PEIS) .....	7
Potentiostatic EIS and Setup Parameters.....	7
Galvanostatic Electrochemical Impedance Spectroscopy (GEIS) .....	9
Galvanostatic EIS and Setup Parameters.....	9
Galvanostatic HFR (GHFR).....	9
Galvanostatic HFR and Setup Parameters .....	9
Note on Frequency selection: .....	10
Notes on Potentiostats/Galvanostats .....	10
<b>Hardware Installation .....</b>	<b>11</b>
Front Panel Indicators.....	11
Rear Panel Description .....	11
Typical System Interconnections/ External Cabling to EA163 POTENTIOSTAT.....	12
<b>Software Installation .....</b>	<b>13</b>
<b>System Configuration .....</b>	<b>14</b>
File: .....	14
Device:.....	14
Experiment: .....	15
Operation:.....	15
Tools .....	15
Transient Recorder .....	17
<b>Monitoring and Data recording .....</b>	<b>21</b>
Galvanostatic EIS or Potentiostatic EIS:.....	21
1/13 GEIS or PEIS: .....	21
File destination.....	22

Run/Stop Buttons and Activity Indicators.....	22
Results .....	22
Monitoring .....	23
Lissajous.....	24
Nyquist .....	24
Bode Plot .....	25
Current & Voltage Time and Frequency domain data .....	26
<b>Saving Data 27</b>	
Data storage structure .....	27
Data Storage.....	27
ASCII Data .....	28

# Table of Figures

Figure 1 PEIS Applied Waveform .....	7
Figure 2 Potentiostatic EIS setup window .....	8
Figure 3 GEIS applied waveform .....	9
Figure 4 GHFR Applied waveforms.....	9
Figure 5 Front Panel of Z100.....	11
Figure 6 Rear Panel of Z100.....	11
Figure 7 Z100 cabling to EA163 POTENTIOSTAT .....	12
Figure 8 Z100 Start up screen. ....	13
Figure 9 Start up screen detail.....	14
Figure 10 Device Menu .....	14
Figure 11 Tools Menu .....	15
Figure 12 File converter menu.....	16
Figure 13 Options: File menu .....	16
Figure 14 Options: EIS Menu.....	17
Figure 15 Transient Recorder screen.....	18
Figure 16 Transient recorder >AI Configuration .....	19
Figure 17 Transient Recorder> External P/G.....	19
Figure 18 Start up screen Detail .....	21
Figure 19 Start up summary line .....	21
Figure 20 List of Experiment Steps .....	21
Figure 21 Results Table .....	22
Figure 22 Analysis Status.....	22
Figure 23 Grahics control icon located in the top left hand corner of each screen:.....	23
Figure 24 Monitoring screen .....	23
Figure 25 Lissajous Figure.....	24
Figure 26 Nyquist Plot Section.....	24
Figure 27 Bode Plot.....	25
Figure 28 Bode Plot, Cursor enabled.....	25
Figure 29 Time and Frequency Domain plots.....	26
Figure 30 Structure of the Z# Data folder.....	27
Figure 31 Tools>Options>File menu .....	27
Figure 32 Data file listing .....	28
Figure 33 ASCII data (not all numerical data is shown).....	28
Figure 34 Basic Hardware structure.....	29
Figure 35 Analog Output Channel Block diagram .....	29
Figure 36 Current & Voltage input channels.....	29



# Z100™ Electrochemical Impedance Analyzer

Electrochemical Impedance Spectroscopy (EIS) has emerged as a powerful technique for defining reaction mechanisms and physical structures involved in a wide variety of electrochemical applications including

- Biological systems
- Surface structures
- Corrosion processes
- Battery and fuel cell

The EDAQ Z100™ EIS System provides the means to turn an existing potentiostat/galvanostat into a fully functioning EIS System with full analysis and modeling capability.

The single channel Z100 is based on the experience gained from the development of a 6 channel EIS system and includes many useful enhancements.

The complete system is software controlled and all functions such as ranging, calibration, and measurements can be automated.

This manual describes the Z100 Navigator software application which controls and sets up the operating parameters of the Z100 system. Standard Features for the Z100 include the following:

- Specially Designed for AC Impedance Experiments
- Versatile Waveform Generator/Analyzer
- Frequency Range of 1  $\mu$ Hz to 100 kHz
- Data Presentation, Analysis and Modeling with ZMAN software
- 1 Output for the Excitation voltage
- 2 Analog Inputs: 1 for Current and 1 for Voltage Response Auto ranging
- High Speed USB Interface

With the help of Z100 Navigator software, the Z100 and EDAQ EA163 potentiostat provide the means to perform a number of common electrochemical impedance spectroscopy (EIS) experiments.

The available techniques and Setup Parameters are described in the sections that follow and are detailed below — Available techniques.

## Available Techniques

The basic function of the Z100 is to generate predefined periodic excitation waveforms, apply them to a system under test and to measure the resulting current and voltage magnitude and phase responses simultaneously. The Z100 system is normally supplied with an EA163 POTENTIOSTAT connected via I2C bus to the Z100. This configuration supports PEIS, GEIS & GHFR.

3rd party potentiostats/galvanostats and Electronic Loads are also supported – contact EDAQ for details. With waveforms and analysis methods provided, the following EIS techniques are available with Z100 Navigator software.

### List of Techniques

With an EA163 POTENTIOSTAT or 3rd party potentiostat/galvanostat

- Potentiostatic Electrochemical Impedance Spectroscopy (PEIS)
- Galvanostatic Electrochemical Impedance Spectroscopy (GEIS)
- Galvanostatic High Frequency Resistometry (GHFR)

Other techniques can be implemented with the Z100 – contact eDAQ to discuss your application.

## Potentiostatic Electrochemical Impedance Spectroscopy (PEIS)

The Z100 can measure a full impedance spectrum over a selected frequency range using the EA163 POTENTIOSTAT in potentiostatic mode. The sample under test is driven by a small AC potential superimposed on a DC (Bias) Potential (Figure 1). The resulting AC current magnitude and phase is measured. This is repeated for every selected frequency to build up the impedance spectrum.

The parameters that are accessible to control the experiment are detailed below.

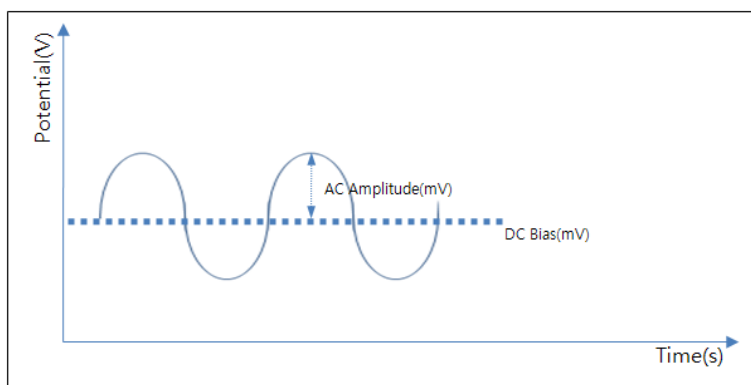

Figure 1 PEIS Applied Waveform

### Potentiostatic EIS and Setup Parameters

Parameters listed below and displayed in Figure 2 can be changed or alternatives selected by double clicking on the item.

*Delay, Delay Time [s], Delay Stability [mV/s]: Reserved for future use*

**DC Potential:** DC potential applied to sample during experiment. Default 0 Volts.

**AC Amplitude:** Amplitude of sinusoidal excitation superimposed on DC Potential. Default 100mV.

**Initial Frequency [Hz]:** The starting frequency. See Note on Frequency selection below.

**Mid Frequency [Hz]:** The frequency at which the frequency steps alter their direction.

**Final Frequency [Hz]:** The final frequency reached.

**Density [points/decade]:** Sets the number of points in a frequency sweep decade. Typical value is 10/decade. It can range from 1 to 5000. Default is 5 points/frequency decade.

**Iteration:** Sets the number of frequency sweeps performed. Default is 1.

**Current Range [mA]:** Sets the required POTENTIOSTAT current range. Typically start at 10mA range.

**Cycle Limit:** Number of high frequency cycles measured. High frequency measurements are subject to noise and increasing Cycle limits may reduce this effect through averaging.

**Min Cycle:** minimum number of cycles measured at slow speeds

**Time Limit:** Max time per frequency provided Minimum cycles is executed.

**Cell:** selects one of 3 conditions:

**Standby:** in this state the potentiostat will be disconnected from the external cell. When an experiment is performed the external cell will be automatically connected to the potentiostat, the experiment completed and the external cell is then automatically disconnected.

**Dummy:** The potentiostat is connected to the internal 100 kohm dummy cell.

**Real Cell:** in this state the real cell is connected to the potentiostat and remains connected.

**High Stability:** sets Hi Stability mode (reduced frequency response) True ON– False –OFF. This setting is used if the external cell characteristics induce an unstable state (Oscillation). This condition is automatically invoked in the galvanostatic mode.

**Phase correction:** Corrects for phase shift due to instrumentation. True ON, False Off

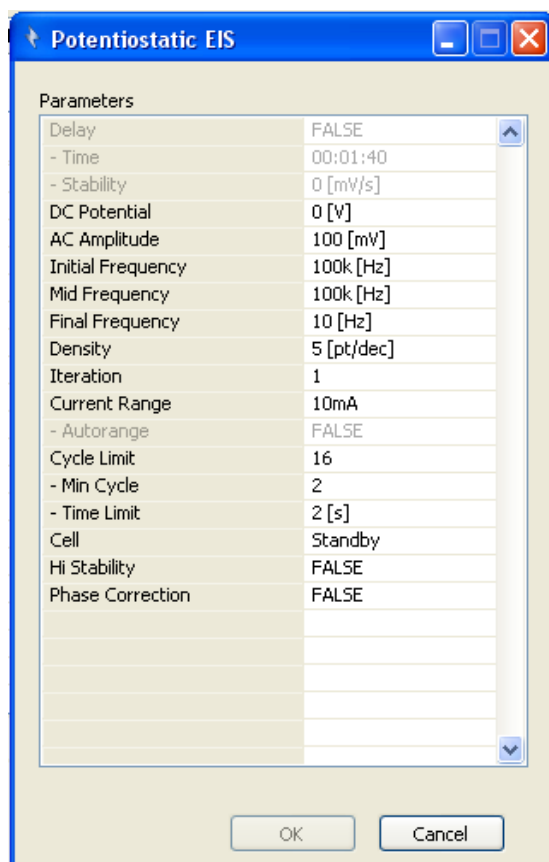

Figure 2 Potentiostatic EIS setup window



## Galvanostatic Electrochemical Impedance Spectroscopy (GEIS)

The Z100 will measure a full impedance spectrum using the EA163 POTENTIOSTAT in galvanostatic mode. The sample under test is driven by a small AC current superimposed on a DC (Bias) Current (Figure 3). The resulting AC voltage magnitude and phase is measured. This is repeated for every selected frequency to build up the impedance spectrum.

The parameters that are accessible to control the experiment are detailed below.

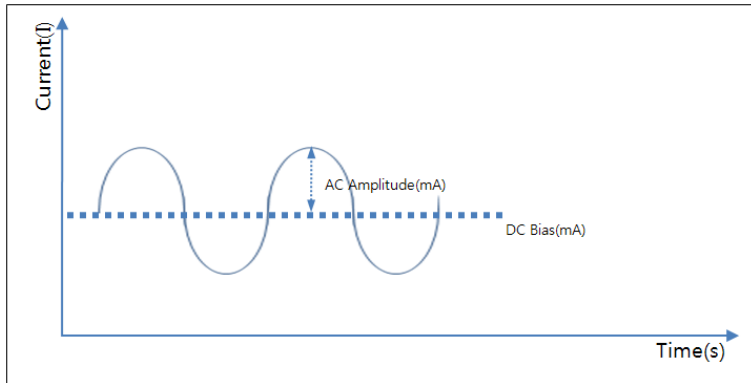

Figure 3 GEIS applied waveform

### Galvanostatic EIS and Setup Parameters

A List of Setup Parameters similar to those described above is available to setup conditions for a GEIS experiment.

### Galvanostatic HFR (GHFR)

Z100 will measure time-evolved impedance data at fixed frequencies, see Figure 4, using the EA163 POTENTIOSTAT operating in the galvanostat mode.

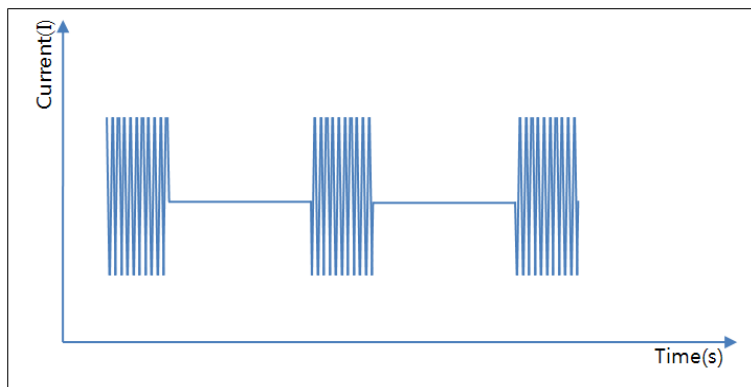

Figure 4 GHFR Applied waveforms

### Galvanostatic HFR and Setup Parameters

List of Setup Parameters

*Delay, Delay Time [s], Delay Stability [mV/s]: Reserved for future*

**DC Current [mA] +AC Amplitude [mA]:** Small sinusoidal perturbation signal with amplitude of **AC Amplitude** is superimposed on **DC Current**.

**Frequency [Hz]:** To set a single frequency

**Iteration:** To set how many measurements will take

**Interval [s]:** To set interval between two successive measurements.

**Current Range [mA]:** To set desired current range of EA163 POTENTIOSTAT

#### Note on Frequency selection:

Frequency will be scanned from “initial” to “mid” and stop on “final”. The scan has no preferred direction – the system can scan from high to low or low to high. The typical and preferred direction of frequency scanning is from high to low. Scanning at high frequencies is faster and inappropriate settings can be more quickly identified. Scanning at low frequencies, for example at 1mHz, takes 1000 seconds to complete one frequency so it’s a long time to wait to detect an error.

To scan from one frequency value to another two of the values can be the same as shown below:

**Initial Frequency: 1Hz**

**Middle Frequency: 20Hz**

**Final Frequency: 20 kHz**

These settings will scan from 1Hz to 20 kHz

**Initial Frequency: 10 kHz**

**Middle Frequency: 1 Hz**

**Final Frequency: 10k Hz**

These settings will scan from 10 kHz to 1Hz and back to 10 kHz.

**Initial Frequency: 1 kHz**

**Middle Frequency: 1 kHz**

**Final Frequency: 1 kHz**

**Iteration = 100**

These settings will repeat a single frequency (1 kHz) 100 times.

#### Notes on Potentiostats/Galvanostats

The Z100 system is designed to operate at its rated 100 kHz Bandwidth with minimum internal phase shift. External Potentiostats/ Galvanostats, their internal settings, input cables and the External Cell being tested will all affect the Magnitude and Phase response and the stability of the system.

The EA163 potentiostat operates with a <5 degree phase @100 kHz bandwidth at 100mA, 10mA and 1mA ranges, 10uA @15kHz and 1uA and below at 1.5 kHz. Measurement of high impedances requires operations at lower bandwidths. In Galvanostat Modes similar performance is attainable but in this case the possibility of instability (parasitic oscillations) is more likely due to the external cell and in such case High Stability option is available that restricts operation to 1.6 kHz.

# Hardware Installation

Connect the hardware as shown below:

System Requirements:

P4 or above CPU, Memory >512M,

Support USB port, suitable for WIN XP, Vista 32 or Windows 7 OS.

## Front Panel Indicators

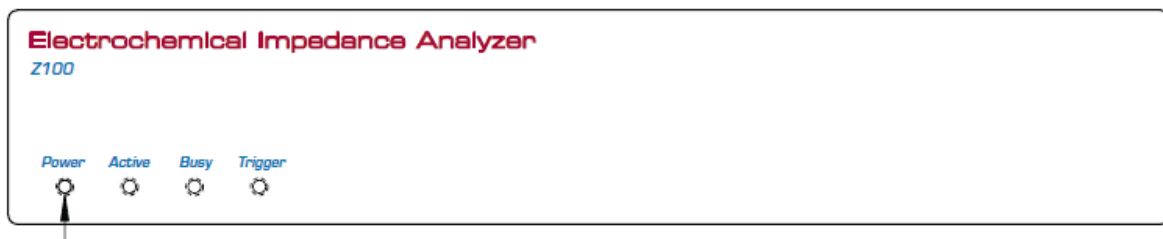

Figure 5 Front Panel of Z100

**Power:** Power ON indicator

**Active:** ON when ready to run a measurement.

**Busy:** It's blinking when Z100 was running.

**Trigger:** On when triggered

## Rear Panel Description

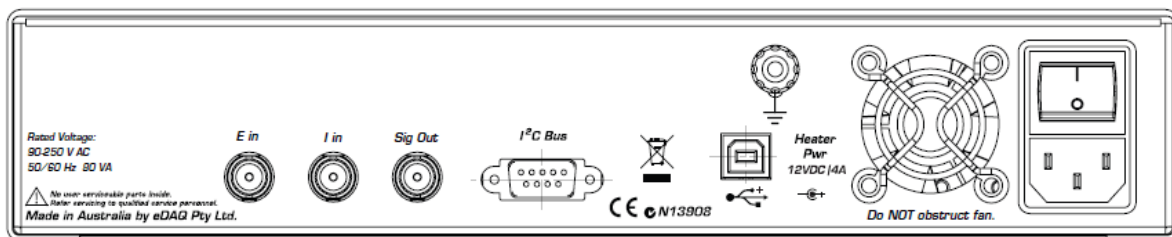

Figure 6 Rear Panel of Z100

**Ein:** Voltage signal input from Potentiostat

**Iin:** Current signal input from Potentiostat

**Sig Out:** Excitation signal from Z100 to potentiostat

**I²C Bus:** Communications cable to Potentiostat

**USB:** Communications cable to Computer USB port

**Power:** Mains input

## Typical System Interconnections/ External Cabling to EA163 POTENTIostat

Refer to factory for connection to other potentiostat

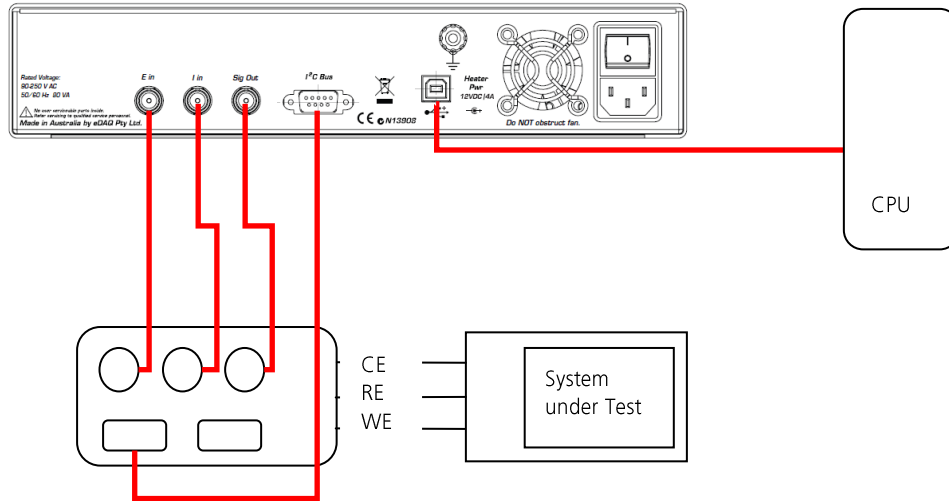

Figure 7 Z100 cabling to EA163 POTENTIostat

When your hardware has been connected as shown in Figure 7, apply power – all indicator lights should come on momentarily and then go off except for the Green Power LED and the Active LED. The potentiostat should indicate that it is OFF Line (green LED off) and the Overload Light is OFF to indicate that there is no overload condition present.

**Note:** the Potentiostat Overload LED will be ON when the system is first switched on in order to confirm that the Overload circuit is operational. The Overload light may remain ON until the Potentiostat is accessed by the software for the first time at which point it the Overload light will be reset.

Your software can now be installed.

## Software Installation

Insert your software CD in the CD tray.

Run Setup.exe and follow on screen prompts. Once installation is complete both Z100 Navigator and ZMAN applications should be available in your Program folder and short-cut icons should appear on your desk top. Click on the Z100 Navigator icon to initiate the program. On start up the Z100 Navigator window will be displayed and will indicate that the Z100 and the attached potentiostat have been detected (see below).



On completion of its start up process – which can take up to a minute- the following Start up screen will be displayed (Figure 8) to indicate that the system is ready for operation. The system is now ready for use.

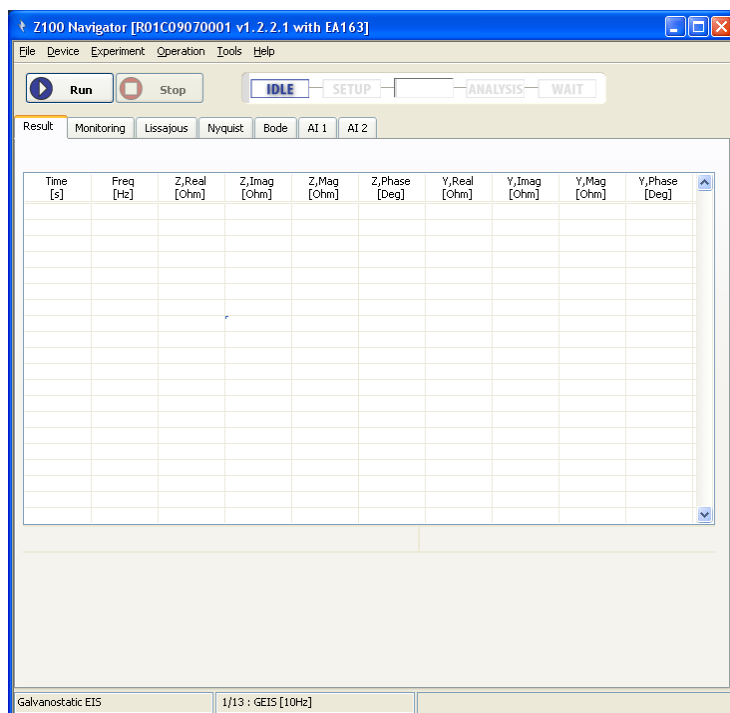

Figure 8 Z100 Start up screen.

## System Configuration

A start up window Figure 9 will be displayed when the application is launched. It consists of a number of menus described below to allow system configuration, experiment setup and provide monitoring and data recording during experiments.

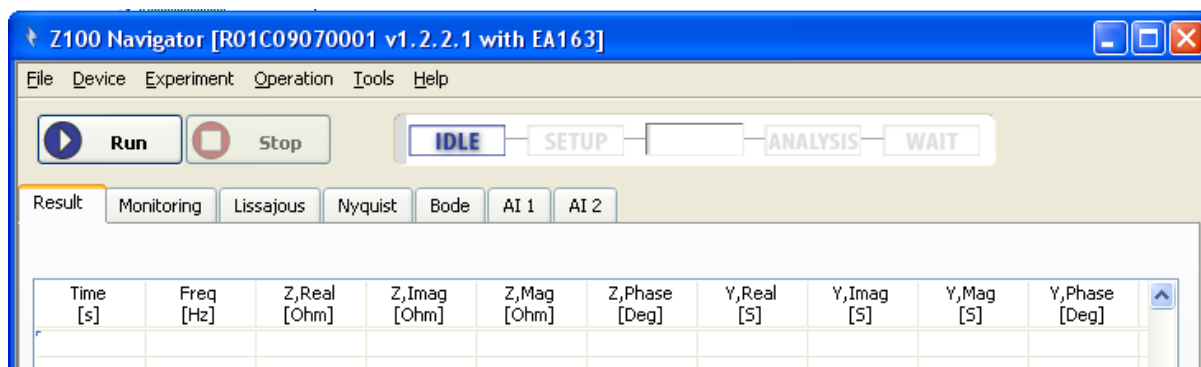

Figure 9 Start up screen detail

### File:

This menu item provides the means to open a file, save a file and open Recently used files. See Saving Data section for more detail on data files naming and structure.

### Device:

This Startup menu item ( Figure 10) provides facilities for detecting initializing and resetting Active Z100 devices and external Potentiostats. Some of these commands relate to circumstances in which multiple Z100 are connected to the system. In most cases the Z100 system connected to your PC will be automatically found, reset and installed and there is no need to initiate any of these commands.

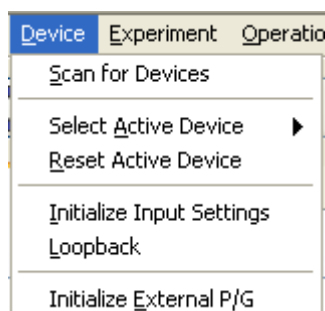

Figure 10 Device Menu

**Loopback:** is an important setting that can be used in order to test the operational integrity of the Z100 system. By selecting this item a self test of the Z100 can be performed – see Z100 Quick Start Manual for details of this procedure.

**Initialize External P/G:** this can be used to reset and initialize the external potentiostat. Typically this command is performed automatically during startup so there will not be a need to perform this command unless some condition occurs that prevents the potentiostat from operating correctly or from being recognized by the Z100 system.

## Experiment:

This is used for selecting the experiment to be performed. Either PEIS, GEIS can be selected and when selected the appropriate setup command menu is displayed.

## Operation:

Start and Stop Function Keys – other function Key initiated operations can be included here.

## Tools:

This menu (Figure 11) provides an important set of commands described below

**Transient recorder:** this provides an independent method of generating a number of waveforms that can be applied to a system under test. A full description is available at the end of this section.

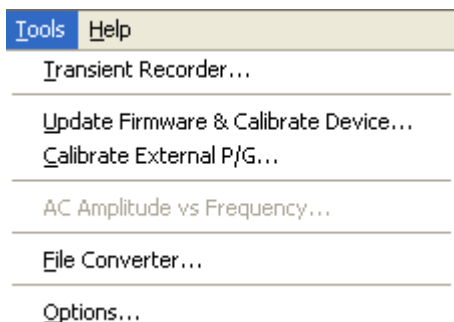

Figure 11 Tools Menu

**Update Firmware & Calibrate Device:** no user intervention is normally required. This command provides means to calibrate the system and upgrade the firmware. The calibration facility is normally performed in the factory so it is not necessary for the user to perform this function. Firmware Updates can be performed when new firmware becomes available and instructions for this operation will be provided with the Firmware upgrade document.

**Calibrate External P/G:** this menu allows the external Potentiostat/Galvanostat to be calibrated. One of the most important aspects of this section is the measurement of the Potentiostat “Blank” phase response so that this data can be used to correct for phase distortion introduced by the Potentiostat and the Z100. See the Z100 Quick start manual for a description of the procedure to perform this task.

**File converter:** Used for converting Z100 native files “Binary file” (\*.wis, \*.wiv) to “ASCII file” (\*.z#, \*.iv#). See Figure 12.

File extension convention:

**\*.wis** > AC Data (Voltage and Current data recorded during an EIS scan) > ASCII file **\*.z#**

**\*.wiv** > DC Data (records DC data recorded during running of Electrochemical techniques such as Cyclic voltametry etc) ASCII file **\*.iv#**. This operation is not currently implemented in Z100 Navigator. DC data is saved when CV, LSV, and SWV techniques are enabled. Currently this feature is not implemented in Z100 Navigator but is planned for future release.

ZMAN 2.2 Analysis and Modeling application supplied with your system will only open Binary File that are generated on the Z100 system (\*.wis files). If analysis of data recorded on other systems is required a standalone ZMAN 2.2 license may be purchased from EDAQ.

Converting your files to the ASCII format (\*.z#) provides the means for this data to be read by other programs. Z100 users may want to export their data to Excel or Origin software for publication. This file converter provides this facility.

Folder for AC data” is stored internally for subsequent use.

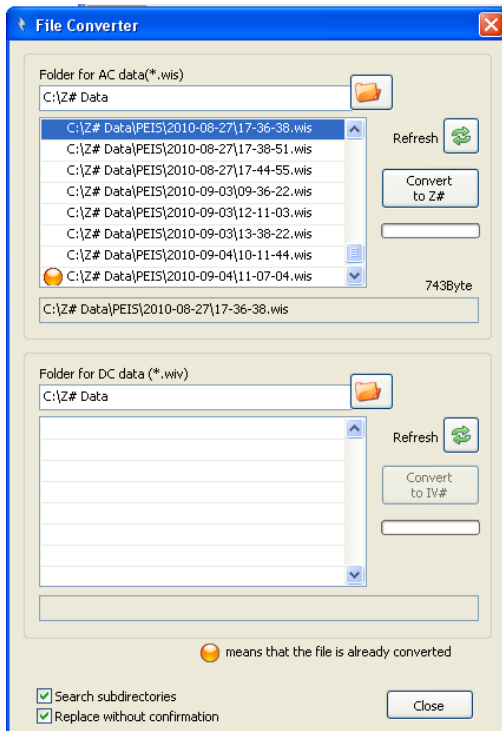

Figure 12 File converter menu

**Options Menu** See Figure 13 and the following sub- menus

**General:** some general set up commands defining start up scanning and conditions to be set at the conclusion of an experiment.

**File:** Allows control of and file management settings. If **Automatically save data** option is selected, **Automatic file name** and **Data file format** are enabled. See Fig 14

If the **Automatic file name** is enabled, EIS data is saved automatically in the **Folder for AC data**. File format can be binary or ASCII.

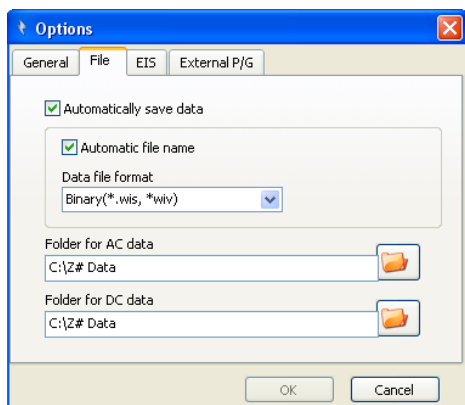

Figure 13 Options: File menu

If **Automatically save data** option is not enabled, data is not saved until you select **File >Save As Binary Format...** or **Save as ASCII Format...** in the **File** menu in the Main window.



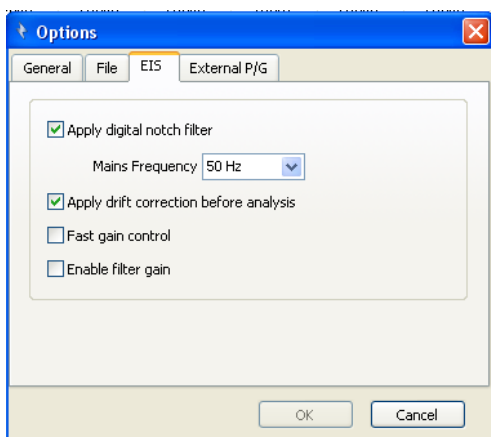

Figure 14 Options: EIS Menu

**Options: EIS:** See Figure 14

**Apply digital notch filter:** controls whether to use the internal digital notch filter. Select appropriate mains frequency in your area.

**Apply drift correction before analysis:** During recording of an impedance spectrum, a potential drift can occur. The magnitude of drift is time dependent and can be compensated by software during the measurement.

The formula is  $E_{\text{measured}}(t) = E_{\text{true}}(t) + a \cdot t + b$  and we can get  $E_{\text{true}}(t)$  by linear regression.

**Fast gain control:** If true, PGA gain of each channel is calculated from the measured impedance and set automatically to the most appropriate value. This can achieve faster EIS results.

If false, PGA gain is set by an iterative step-by-step procedure: if the signal is too big, a lower gain is chosen and if the signal is too small, a higher one is selected. It is useful to measure very small impedances. In this case, measured impedance using inappropriate PGA gain may be significantly in error.

**Enable Filter Gain:** PGA amplifier has up to +40 dB of gain (x100). The analog filter can provide an additional X10 gain. It is useful in measuring very low impedance (i.e. ~100uV amplitude of sine wave); however, calibration is not available at this extra gain.

**External P/G:** these controls provide some control of external 3<sup>rd</sup> party Potentiostats. Because the EA163 is recognized by the Z100 system and can communicate with the system directly its control functions are available in the Z100 Navigator application.

## Transient Recorder

The transient recorder module contains a number of systems that allow control over the various elements of the Z100 system and a potentiostat attached to the system and in addition provide an independent means to generate waveforms to test system performance. The notes below describe the various functions provided by this software module (see Figure 15).

**Hardware Appendix:** Please refer to this Appendix when reading this section, it will provide some useful information that will assist in understanding some of the hardware related features of this system.

**Important Note:** Some of the settings in this menu can affect the same system parameter from two locations: from within the Transient Recorder menu or from the Experiment Set up menu. Each location can control its own settings.

**Analog Out:** This section provides control over the Analog output excitation provided by the system and appearing on the Sig Out terminal of the Z100. The following parameters are accessible:

**Bias Voltage:** A DC bias or DC potential can be applied to the sample under test. Maximum allowed voltage is +/-10 Volts therefore the combination of DC bias and AC amplitude must not exceed 10Volts.

**Cut Off Frequency:** a user selectable filter may be applied to the output waveform.

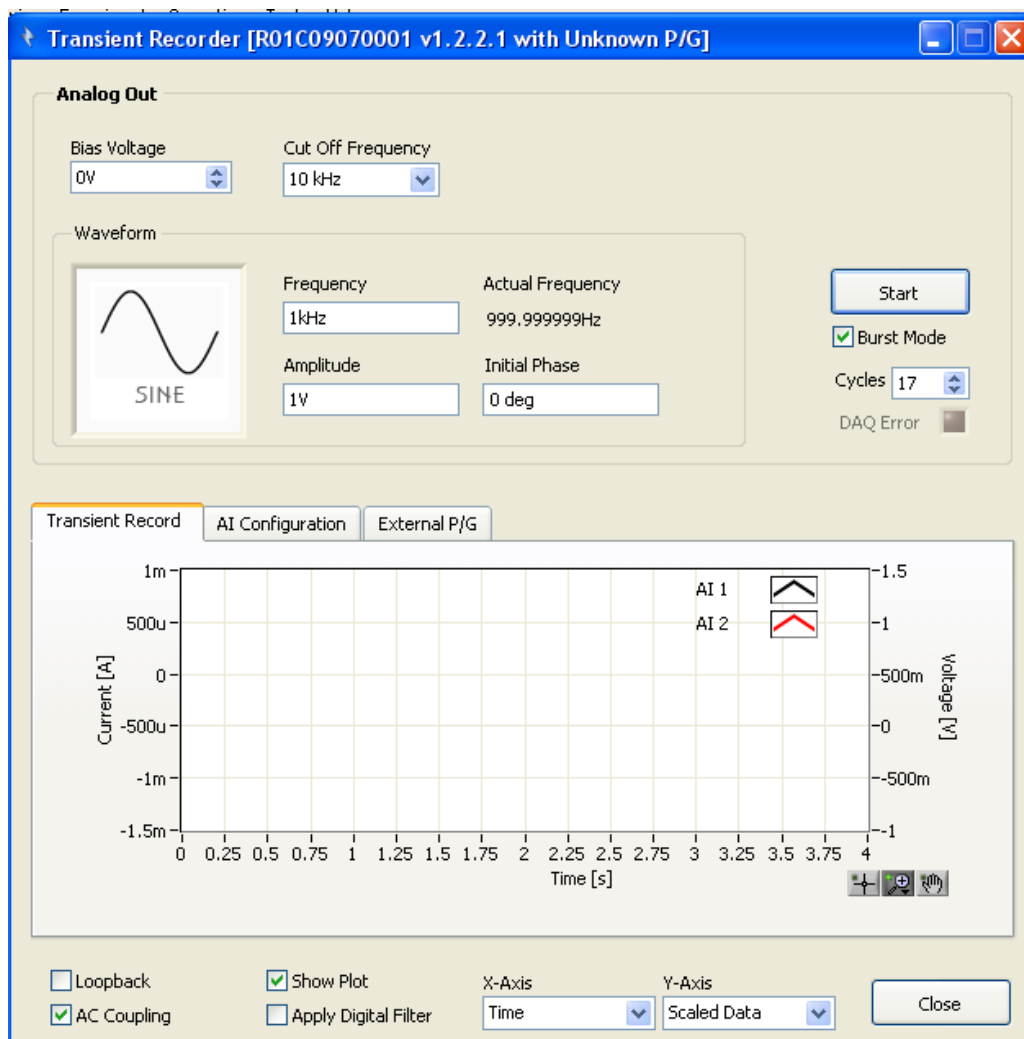

Figure 15 Transient Recorder screen

**Waveform:** Various waveforms can be selected and in addition arbitrary waveforms defined by an analytical function can be generated and output at amplitudes, frequencies and Initial phase specified in the menu. Waveforms can be output continuously or in **Burst mode** and when this is enabled the number of cycles in a burst mode can be specified.

**Transient Record:** This displays both the current and voltage appearing at **I in** and **E in** terminals of the Z100. Axis Scaling will be automatic and any distortion will be visible.

### AI Configuration

This tag provides information on the conditions applying to the last experiment. The two columns refer to the current and voltage channel and provide further diagnostic information.

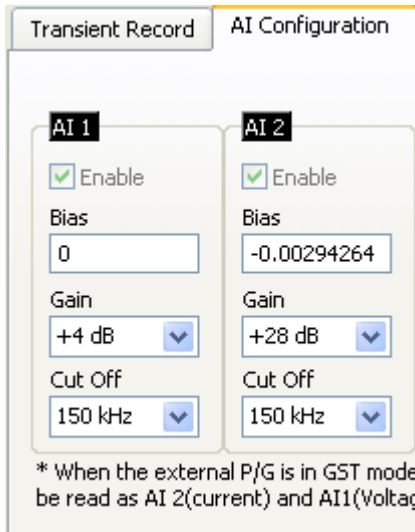

Figure 16 Transient recorder >AI Configuration

The above settings (see Figure 16) allow the user to control the gains of the Current and voltage amplifiers as well as any applied bias, if there is distortion visible – reduce the gain and if there is too much noise then increase the gain.

### External P/G

This menu provides the means to set the operating parameters of the external Potentiostat/Galvanostat. The **Mode, Current Range and Filter** setting, **High Stab** mode used in Galvanostatic operations and the Cell arrangement can be configured.

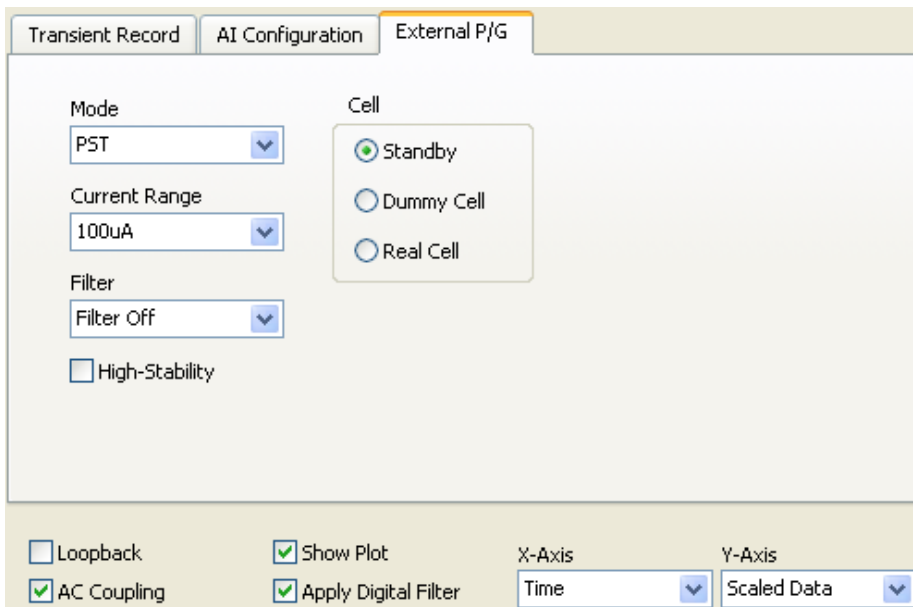

Figure 17 Transient Recorder> External P/G

**Cell Configuration:**

**Standby:** in this mode the system is internally connected to the Dummy cell and the connections to the external cell are all "open" so that the system can have no effect on the external cell. If this setting is chosen the system will switch to the Real Cell when the experiment begins and switches back to Standby mode at the completion of the experiment.

**Dummy Cell:** this setting connects the potentiostat to the internal 100 kohm internal cell

**Real Cell:** this setting connects the potentiostat to the External (Real) Cell. Any experiment will be performed on this cell and at the end of the experiment the cell will stay connected.

**Loopback:** Connects the Z100 output to its input in order to test the system with no external devices. See Quick Start manual.

**AC coupling:** See Hardware ADDENDUM. This setting removes any DC offset.

**Apply Digital Filters:** See Hardware ADDENDUM. Applies post acquisition digital filters.

**X and Y axis:** These controls allow the display in real units (time and Current or voltage) or in actual ADC readings (number and value). This can be used as a diagnostic test to show if the ADC converter is operating within its linear limits.

## Monitoring and Data recording

This section describes the monitoring and recording features of the software. The contents and functions of the various buttons and menu items will be described below.

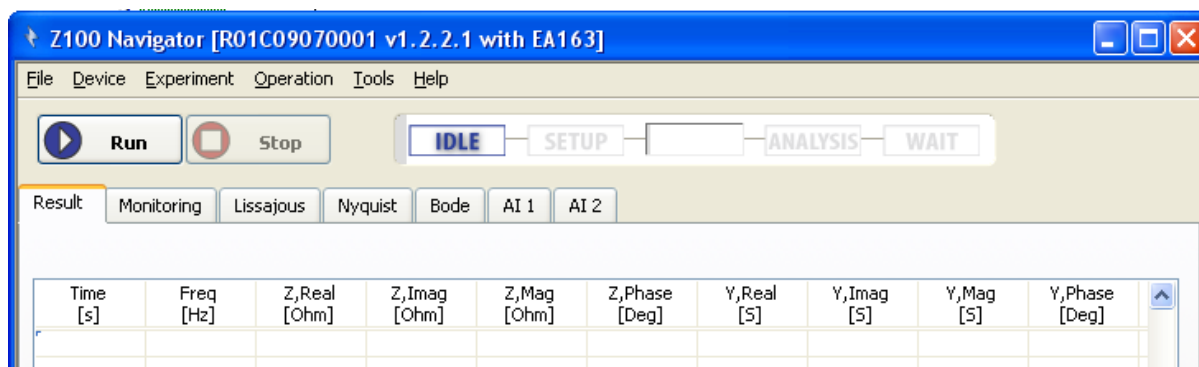

Figure 18 Start up screen Detail

At the bottom of the startup screen there are three items which will first be described.

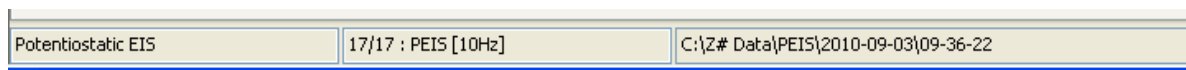

Figure 19 Start up summary line

### Galvanostatic EIS or Potentiostatic EIS:

Accessing this item brings up a Command menu (see Fig 2) that allows either a PEIS or GEIS experimental conditions to be defined. The experiment that will be run when the Run button is activated is defined here.

### 1/13 GEIS or PEIS:

This item brings up the complete list of steps that will be undertaken in carrying out the next experiment. During data acquisition this item will indicate the step reached.

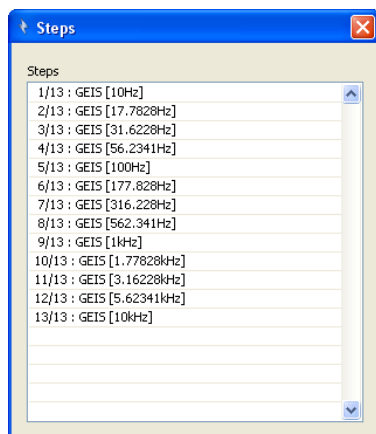

Figure 20 List of Experiment Steps

## File destination

The destination of the experiment file will be automatically generated by the system and the location will be displayed in the RHS cell.

## Run/Stop Buttons and Activity Indicators

These commands START and STOP an experiment and indicate progress as the experiment proceeds.

The **Start** command will begin the experiment and it can be terminated at any time by the **Stop** command –waiting until the experiment is completed will result in a complete data file stored in the location indicated at the bottom RHS of the display.

## Results

Once an experiment is started and data obtained it will be displayed in the Results table.

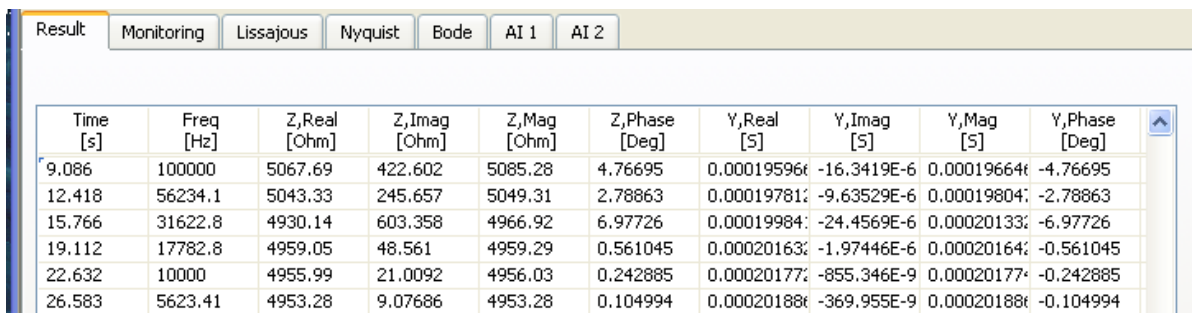

The screenshot shows a software interface with a 'Result' tab selected. Below the tabs are several menu options: Monitoring, Lissajous, Nyquist, Bode, AI 1, and AI 2. The main area displays a table with 10 columns: Time [s], Freq [Hz], Z,Real [Ohm], Z,Imag [Ohm], Z,Mag [Ohm], Z,Phase [Deg], Y,Real [S], Y,Imag [S], Y,Mag [S], and Y,Phase [Deg]. The table contains 7 rows of data.

Time [s]	Freq [Hz]	Z,Real [Ohm]	Z,Imag [Ohm]	Z,Mag [Ohm]	Z,Phase [Deg]	Y,Real [S]	Y,Imag [S]	Y,Mag [S]	Y,Phase [Deg]
9.086	100000	5067.69	422.602	5085.28	4.76695	0.000195966	-16.3419E-6	0.000196646	-4.76695
12.418	56234.1	5043.33	245.657	5049.31	2.78863	0.000197812	-9.63529E-6	0.000198047	-2.78863
15.766	31622.8	4930.14	603.358	4966.92	6.97726	0.000199847	-24.4569E-6	0.000201332	-6.97726
19.112	17782.8	4959.05	48.561	4959.29	0.561045	0.000201632	-1.97446E-6	0.000201647	-0.561045
22.632	10000	4955.99	21.0092	4956.03	0.242885	0.000201772	-855.346E-9	0.000201777	-0.242885
26.583	5623.41	4953.28	9.07686	4953.28	0.104994	0.000201882	-369.955E-9	0.000201887	-0.104994

Figure 21 Results Table

When an experiment is started the system displays an Analysis Status (see Figure 22) which will indicate the condition of the input signals. As the system automatically adjusts for optimum settings it will be indicated that at some settings the signals may be too noisy, too small or too large. Eventually it will indicate that All channels are OK and measurements can proceed and the above table of results displayed. It is for this reason that it is advised that experiments start from High frequencies as these measurements can be done more quickly in case some problems prevent optimum conditions to be found. If appropriate conditions are not found the system will try a number of times and then stop. Connections to the system under test should be checked and possibly new experimental or equipment parameters should be selected.

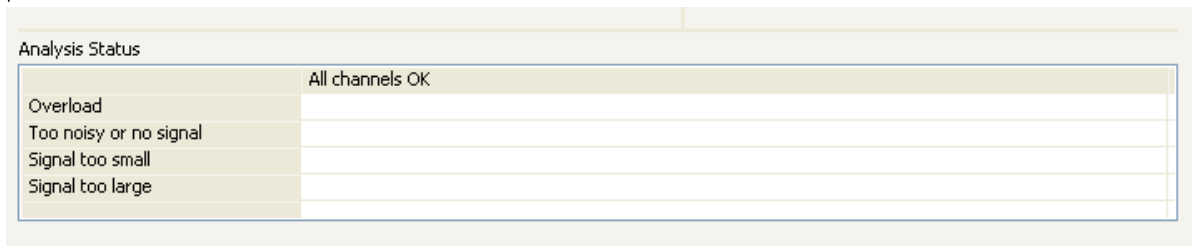

The screenshot shows an 'Analysis Status' window. It contains a table with the following content:

Analysis Status	
	All channels OK
Overload	
Too noisy or no signal	
Signal too small	
Signal too large	

Figure 22 Analysis Status

As the experiment proceeds results will be displayed as a table of real and imaginary impedance and admittance values as well as in various graphical forms accessible at any time during the experiment by selecting the other menus available in this screen:

**Monitoring:** display voltage and current waveforms

**Lissajous:** displays an x-y plot of current and voltage data highlighting phase shifts

**Nyquist:** displays real vs imaginary impedance

**Bode:** displays amplitude and phase vs Frequency

**AI1:** Current vs Frequency, spectral and error data

**AI2:** Voltage vs Frequency, spectral and error data

These screens display various forms of the data and a number of common controls are available to assist in the evaluation of this data. These common graphical features are described below:

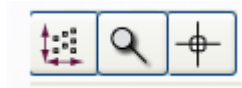

**Figure 23** Graphics control icon located in the top left hand corner of each screen:

The first Icon rescales the data to fit in the display.

The second icon opens and closes a Graph Palette  at the bottom right hand corner that provides the means to magnify move and select sections of the display. The third icon brings up a cursor that displays X and Y values of cursor position. The cursor is constrained to move to experimental data.

Clicking with the right button within a graph area brings up a selection that allows various functions such as copy data or graph to clipboard and a subsequent click of the left Button in the same area will bring up various options with regards to graph type, graph color and line type.

The Data display screens available are described below.

## Monitoring

While acquiring experimental data, the Z100 Navigator monitor screen displays the incoming current and voltage waveforms. Typically the PEIS applied voltage will be 100mV and its scale is displayed on the RHS and the Current scale is displayed don the LHS.

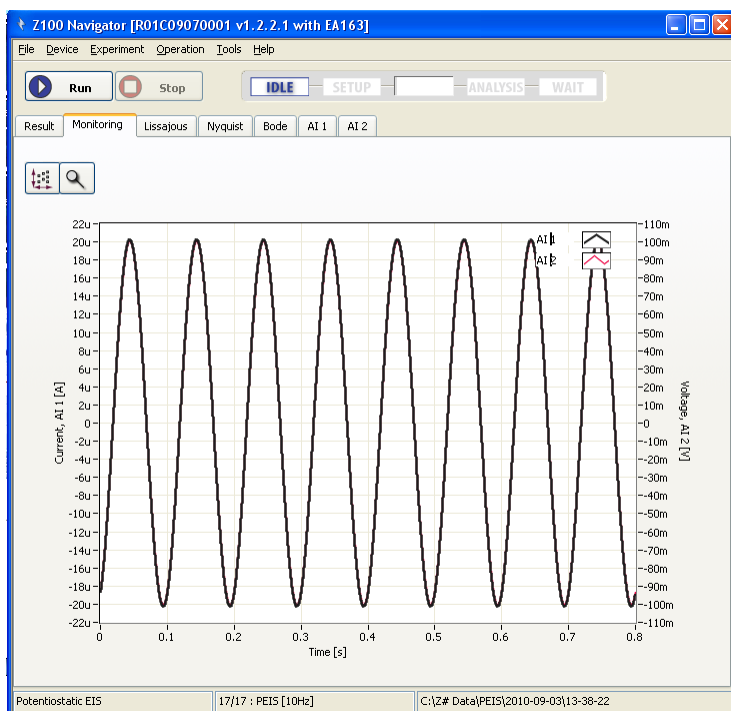

**Figure 24** Monitoring screen

## Lissajous

While acquiring experimental data, the Z100 Navigator Lissajous screen displays the relationship the Current and Voltage waveforms in terms of their phase relationship. A Graphics pallet tool provides the zoom function and the ability to copy the data. Additional pallets as described above provide the means to modify the display in terms of line color and type.

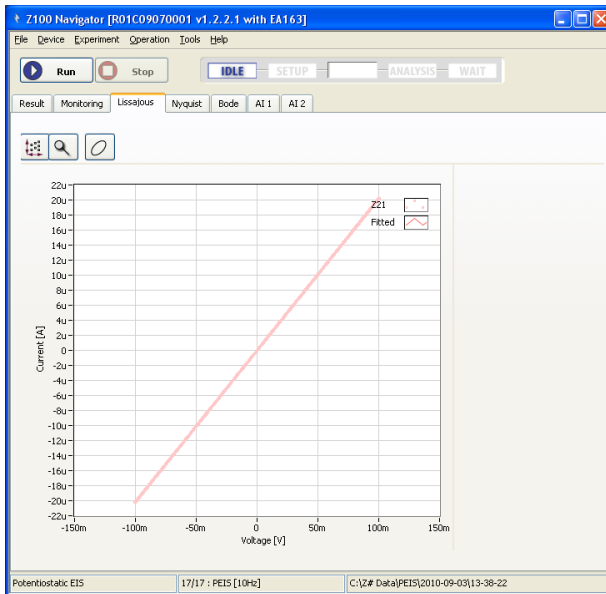

Figure 25 Lissajous Figure

## Nyquist

The Nyquist screen displays a plot of Real and Imaginary Impedance values as shown in the plot below. By clicking in the graph top RHS corner the cursor pallet can be displayed and numerical data associated with each point will be displayed.

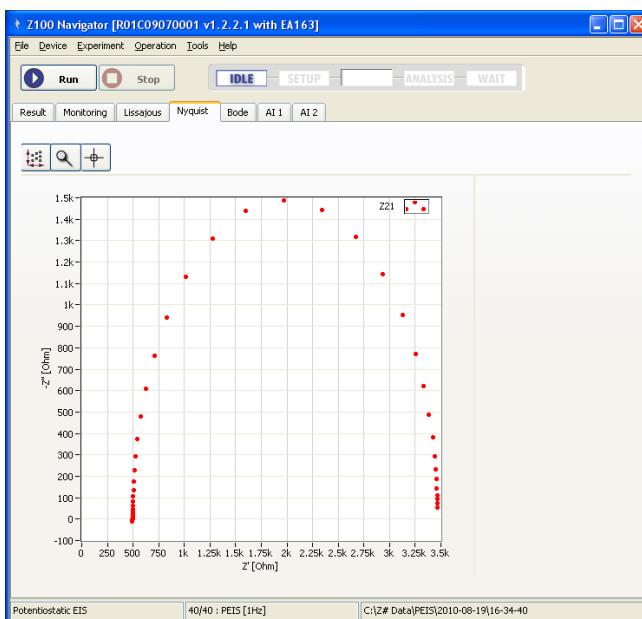

Figure 26 Nyquist Plot Section



# Bode Plot

The plot of signal Magnitude and Phase is displayed in a Bode plot as shown below.

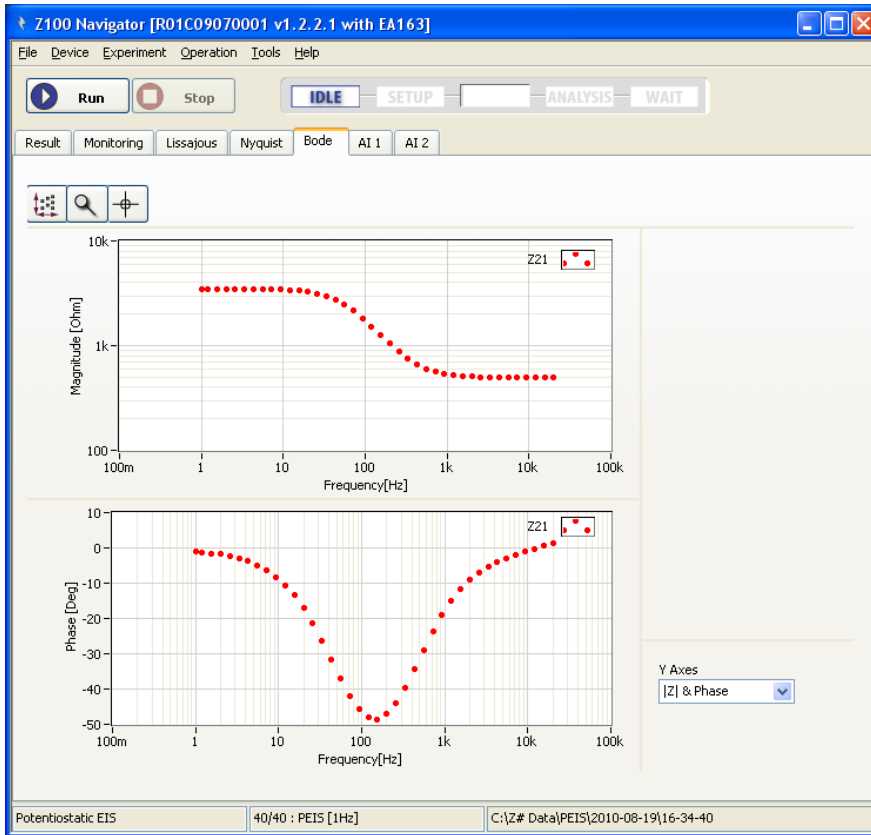

Figure 27 Bode Plot

With the cursor enabled, a view of the data showing numerical values associated with each point, can be provided.

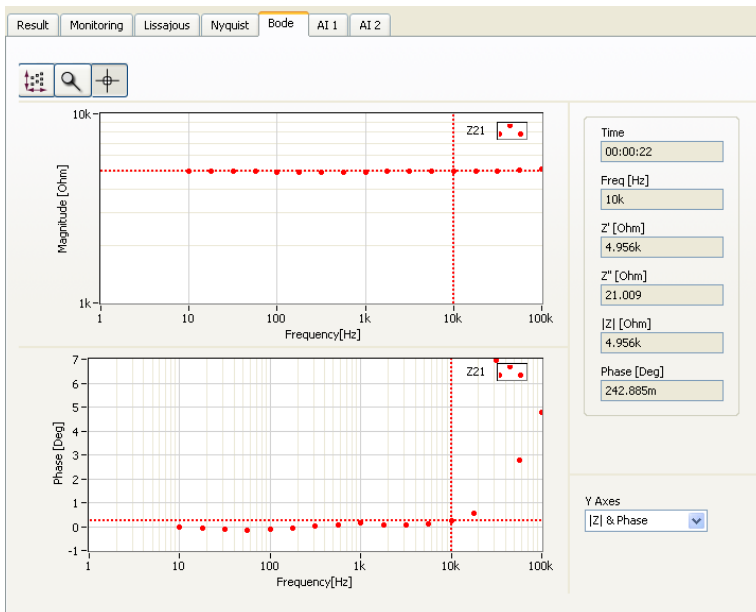

Figure 28 Bode Plot, Cursor enabled

## Current & Voltage Time and Frequency domain data

The top graph displays the raw data, overload data (if exists) and the fitted data. The Z100 Navigator manipulate the raw data by drift correction, offset canceling, and sine-fitting process. The calculation of impedance is based on the fitted data.

The power spectrum graph displays the frequency content of the signal; this is used to evaluate the signal to noise ratio and other error terms. Typical EIS data shows the level of harmonics and noise is below -60 dB (1/1000). You can also evaluate the quality of measurement by Signal in Noise and Distortion (SINAD) and Total Harmonic Distortion and Noise (%THD+N) in the right box. Higher SINAD and lower %THD+N, indicates better measurements.

In most cases the dominant frequency will be the applied frequency and the other terms will be over 1000 times smaller. In the example below the noise frequency terms are individually about 1,000,000 times smaller. As the operating frequency increases in value its noise and distortion component will increase until eventually the measured signal is lost in noise.

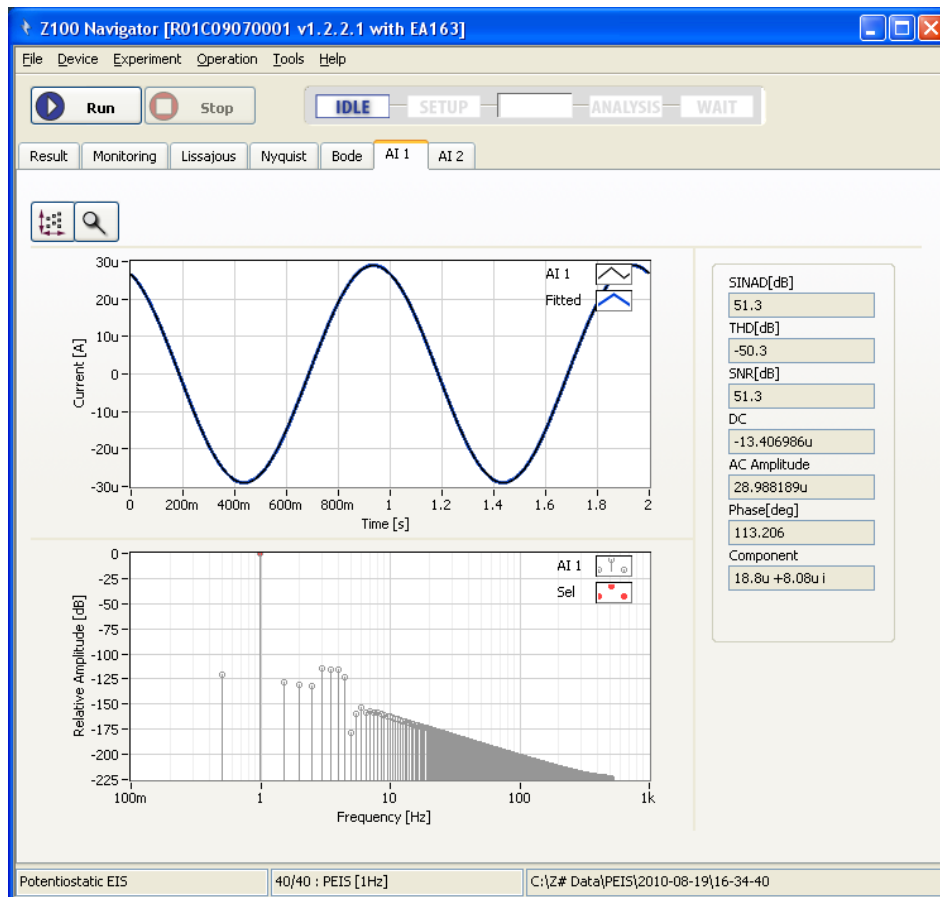

Figure 29 Time and Frequency Domain plots

# Saving Data

In its default mode Z100 Navigator data is saved automatically in C:\Z# Data folder.

## Data storage structure

The Z# Data folder is located in your master hard drive(C:\). Its structure is shown below. Folders are automatically generated for each type of experiments performed on different dates. Data files are automatically generated based on time data. Z100 Navigator thereby manages your data to make it easy to find an experiment or group of experiments for analysis with ZMAN.

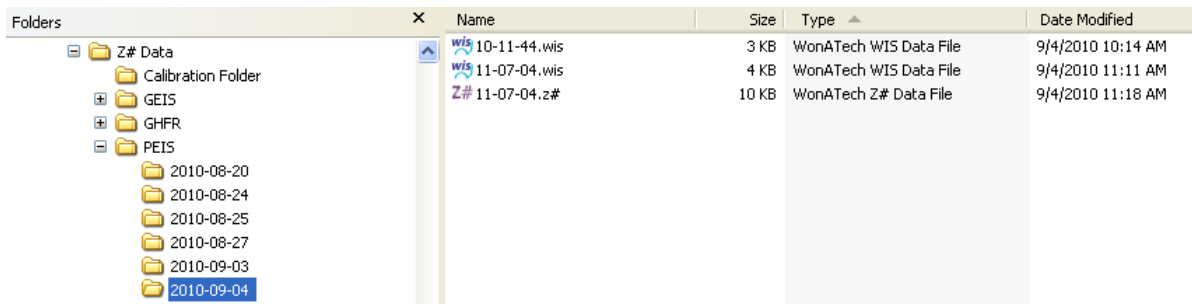

Figure 30 Structure of the Z# Data folder

## Data Storage

Data storage is controlled by **Tools>Options> File** menu. Default conditions are shown in the figure

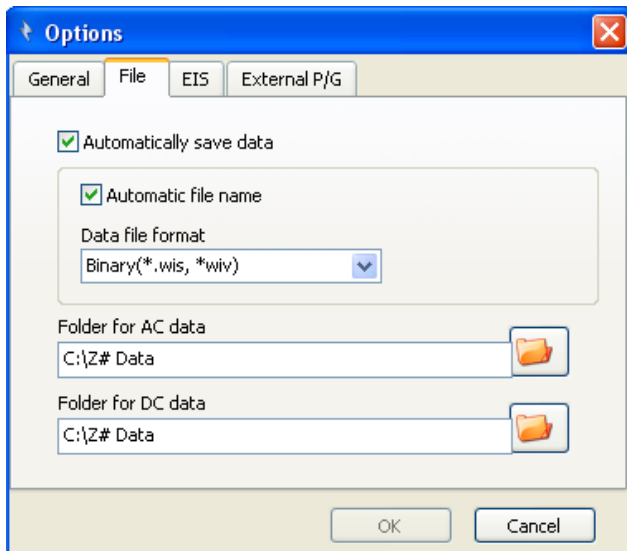

Figure 31 Tools>Options>File menu

By selecting **Automatically save data** the data will be saved in the structure defined above. If this mode is disabled the user will need to perform this function manually.

**Folders for AC Data** specifies the folder where Impedance data will be stored.

**Automatic file name** will generate either Binary (\*.wis) or ASCII (\*.z#) format files with the name generated from the date and time: **Month/Day/ YEAR Hour:Min AM/PM** as shown below.

wis 11-07-04.wis  
Z# 11-07-04.z#

4 KB WonATech WIS Data File  
10 KB WonATech Z# Data File

9/4/2010 11:11 AM  
9/4/2010 11:18 AM

Figure 32 Data file listing

### ASCII Data

Data can also be saved directly from the **File** Menu. This useful if it is required to move the experiment data to an alternative analysis or display program. If ASCII format is selected and the file saved to the desktop the following icon will appear.

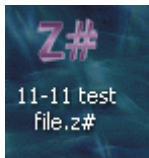

The \*z# file can be viewed with the Windows NotePad and it appears in the tabular format below and includes both the experimental data information and all the numerical data captured by the experiment.

```
File Edit Format View Help
Task : PEIS
DELAY : FALSE
TDELAY : 100 s
SDELAY : 0 mV/s
VDC : 0.000000E+0 V
VAC : 100.000000E+0 mV
FREQINIT : 1.000000E+0 Hz
FREQMID : 1.000000E+0 Hz
FREQFINAL : 100.000000E+3 Hz
DENSITY : 10 Pt/Decade
ITERATION : 1
IRANGE : 1
AUTOIRANGE : FALSE
LIMIT1 : 16
LIMIT2 : 2
LIMIT3 : 2 s
CELL : TRUE
HISTAB : FALSE
PHASE : TRUE

Frequency          Z_Real          Z_Imag          Z_Mag
9.999999995E-1    4.924677834E+3    -5.445145922E+0    4.924680845E+3
1.291549999E+0    4.929796461E+3    3.320925360E+0    4.929797579E+3
1.668100999E+0    4.927542957E+3    -2.159085344E+0    4.927543430E+3
2.154435000E+0    4.921203127E+3    -3.766079660E+0    4.921204568E+3
2.782559000E+0    4.917902154E+3    -6.502588907E+0    4.917906453E+3
3.593813996E+0    4.923725585E+3    -9.662821134E-1    4.923725680E+3
4.641588996E+0    4.919813314E+3    2.336773846E+0    4.919813869E+3
5.994843000E+0    4.924683100E+3    1.939461424E+0    4.924683482E+3
7.742636998E+0    4.921649001E+3    2.227207009E+0    4.921649505E+3
9.999999995E+0    4.925222599E+3    -1.431531978E+0    4.925222807E+3
1.291549698E+1    4.923123005E+3    -2.697989719E+0    4.923123744E+3
1.668100500E+1    4.925356324E+3    -1.138838262E+0    4.925356456E+3
2.154434700E+1    4.921671098E+3    1.926610687E-2    4.921671098E+3
2.782559396E+1    4.924910197E+3    -3.883217683E+0    4.924911728E+3
3.593813700E+1    4.927364608E+3    -4.102999882E+0    4.927366317E+3
```

Figure 33 ASCII data (not all numerical data is shown).

The alternative method of converting Z100 Binary data is by using the **Tools>File converter** menu. In this case only the numerical data is recorded.

## Addendum: Hardware configuration

There is no need to understand the internal hardware and software details of this system in order to be able to use it and produce good results. However some understanding of the internal structure could be helpful in guiding the user to better utilize the features of the system. This addendum provides this background information.

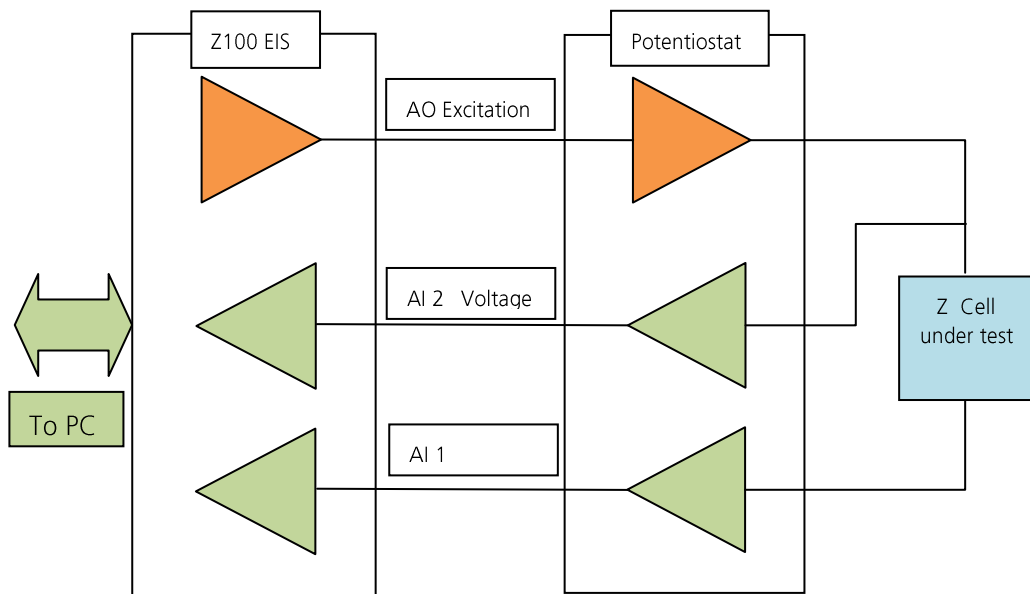

Basic Structure showing the generation of an AO Excitation signal and the subsequent measurement of the AI 1 and AI 2 signals in order to compute the complex impedance

$$Z = AI\ 2/AI\ 1 = \text{Mag \& Phase}$$

**Figure 34 Basic Hardware structure**

waveforms are applied to the potentiostat and the voltages and currents across the Cell under test is measured by the Potentiostat and returned to the Z100 for processing and display.

The first element to be described is the Z100 AO channel (Sig Out). This consists of two precision Digital to Analog Converters (DAC's) one of which generates the Excitation signal and the other generates a DC voltage that is used to apply a Bias or Applied DC potential. These two signals are added to produce a DC level with an excitation signal superimposed. This signal is filtered (reconstruction filter) to remove DAC noise to produce a smooth output waveform. This arrangement is shown in the diagram below.

The Voltage (AI 2) and Current (AI 1) signals are processed by the Z100 to generate the Impedance data. Note that these two channels are identical and in some circumstances may be reversed by the potentiostat when it is operating in Galvanostat mode. (e.g. GEIS).

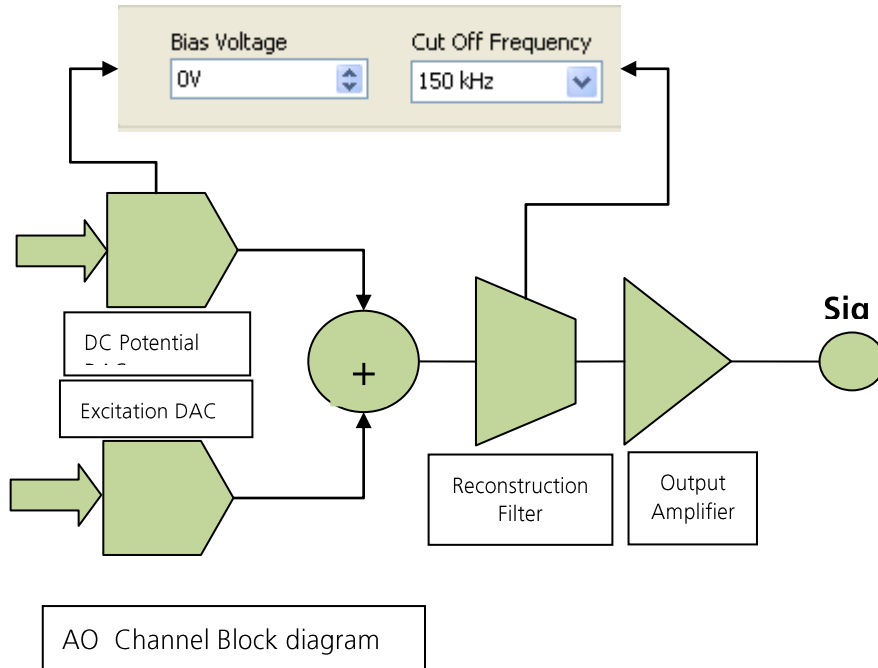

Figure 35 Analog Output Channel Block diagram

These signals will contain two components: a small sinusoidal AC waveform superimposed on a DC value. In order to measure the AC component accurately the DC component must first be removed before the AC waveform can be amplified.

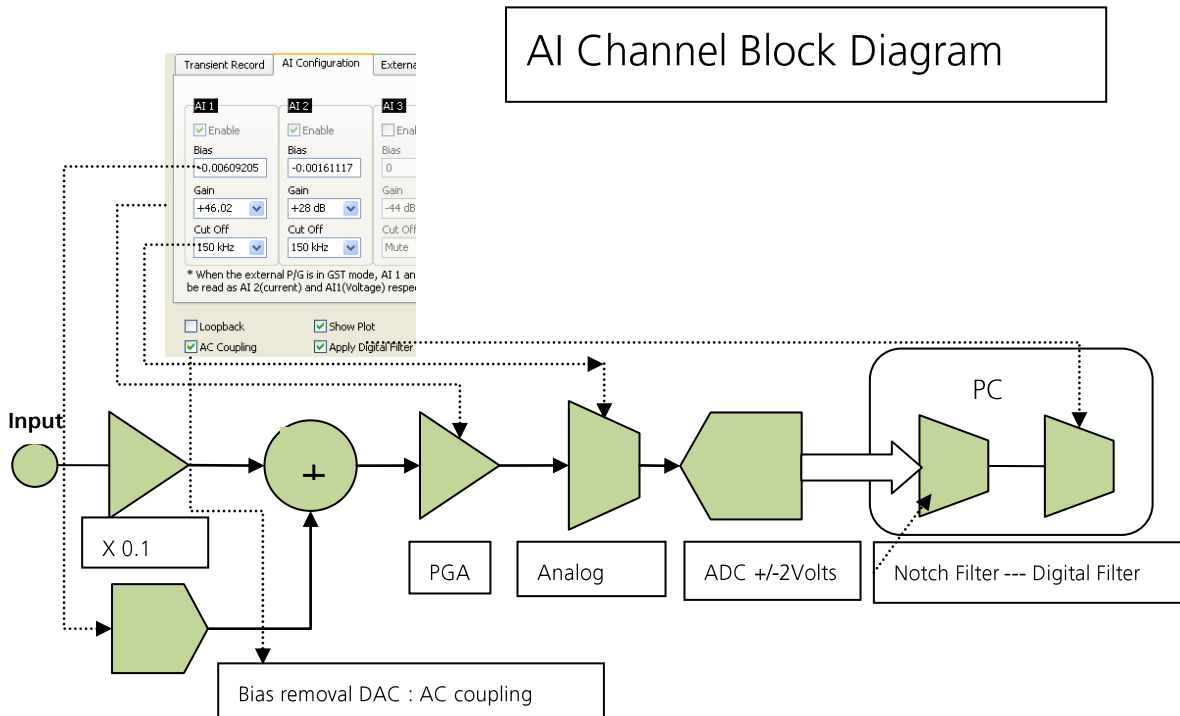

Figure 36 Current & Voltage input channels

To achieve this purpose these identical channels contains the following elements described below.

**x 0.1 Input amplifier** that reduces potentially high input voltages down to a level that the system can handle (<10volts max).

**Bias DAC** provides an adjustable Bias voltage to remove any DC component in the input channel up to +/-100Volts. This enables the PGA to amplify the AC component. This in effect is a form of AC coupling implemented using a DC technique. In some circumstances it may be necessary to add the DC component back into the scaled data. To do this switch off the **AC Coupling** flag and the DC removal will still take place but the value of the DC bias will be added back into the experimental data.

**PGA** Programmable Gain Amplifier can provide adjustable gain with an approximate range of gains from x0.01 to x400.

Note: high gains inevitably result in higher noise levels so ensure that the system operates at levels as high as allowed by experiment being carried out. The output from the PGA must produce a signal in the range of +/-2.000 volts to suit the input range of the ADC.

**Analog Filter** is a Low Pass filter which can be digitally selected from 10 kHz to 150 kHz in 10 kHz steps. PGEIS and PGEIS experiments select this setting automatically to track the frequencies being measured. This filter also has an additional gain of x10 available when really low level signals need to be measured. However adding gain is not without cost and signal to noise ratio is reduced. This additional gain can be controlled in the **Tools>Option>EIS** menu: **enable filter** gain but in most cases this extra gain is not used.

**ADC:** a precision Analog to Digital Converter which converts the analog data for subsequent digital processing.

**Notch Filter** this filter is implemented as a digital filter in the Z100 Navigator application. It is used to remove Mains frequency noise and this must be set in the **Tools>Option>EIS** menu: **Apply digital notch frequency**.

**Digital Filter** this filter is also implemented as a high order digital filter in the Z100 Navigator application. It is a very sharp cut-off frequency filter and when enabled is used automatically to track the filter setting of the analog filter and remove frequencies above the frequency required by the measurement. It can be enabled or disabled **Tools>Option>EIS** menu: **Apply digital filter**.